

### Splash Guards - Front

**Parts List:**

Description	Quantity
Left Splash Guard	1
Right Splash Guard	1
Plastic Push Pin	8
Alcohol Wipe	1

**Tools Required:**

Flat Blade Screwdriver

**Time Required:**

0.5 Hours Per Pair

**Installation Instructions:**

1. Turn wheels all the way in one direction to allow work area clearing.
2. Parts and vehicle temperature must be between 61°F and 86°F (16°C and 31°C).
3. Remove the 4 existing push pins from the fender lip using a flat blade screwdriver or putty knife and discard. Figure 1.

**FIGURE 1**

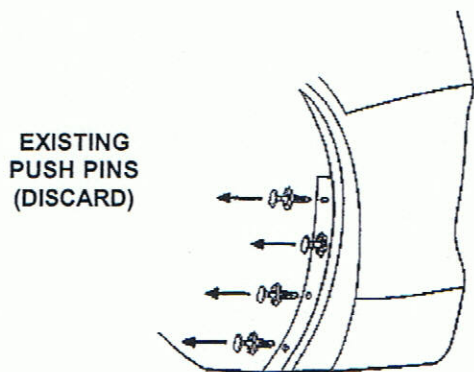

4. Clean the outside fender area where guard will touch, using the supplied alcohol wipe, or 50% alcohol and water.
5. Place the guard against the fender to get familiar with the fit.

6. Insert the supplied push pins in the inner holes of the splash guard and push the center of the pins about half way in to hold the guard in place. Figure 2.

**FIGURE 2**

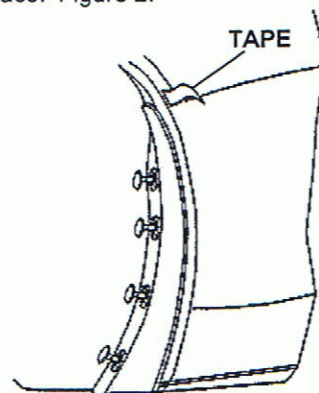

7. Remove the tape backing strip by pulling the tab.
8. Re-check the alignment of the guard to the fender and the ground and press into position, ironing the tape into place, starting at the lower end and working up and using 20-30lbs. of force. Figure 3.

**FIGURE 3**

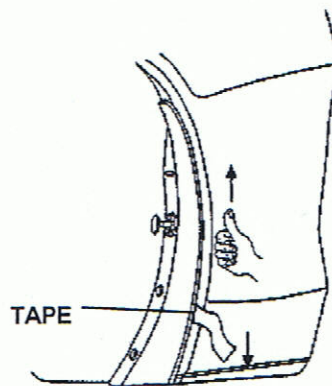

9. Push all four pin heads into pin body. Figure 4.

**FIGURE 4**

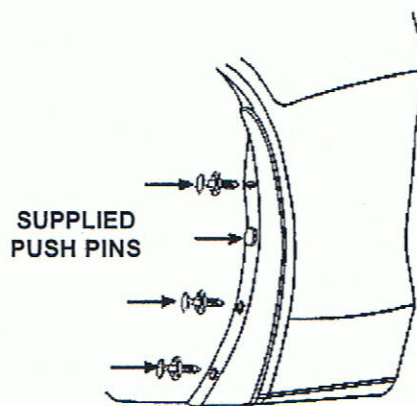

10. Repeat the procedure for the opposite side.

## Splash Guards - Rear

**Parts List:**

Description	Quantity
Left Splash Guard	1
Right Splash Guard	1
Plastic Push Pin	8
Alcohol Wipe	1

**Tools Required:**

Drill with 8.5mm (21/64") Bit

**Time Required:**

0.5 Hours Per Pair

**Installation Instructions:**

1. Remove the rear wheel to allow work area access.
2. Parts and vehicle temperature must be between 61°F and 86°F (16°C and 31°C).
3. Clean the outside fender area where guard will touch, using the supplied alcohol wipe, or 50% alcohol and water.
4. Hold part against fascia, giving special attention to the bottom end of the part (should be against the fascia) and the lower contour at the lower feature line of lower fascia.
5. Engage the top end locator tab to the inside edge of the fascia and hold in place using masking tape. Figure 1.
6. While holding the part in place, mark holes in the liner. Figure 1.

**FIGURE 1**

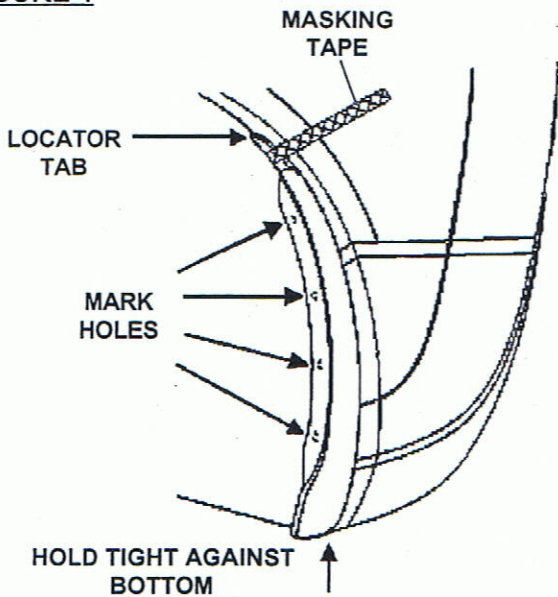

7. Remove the part and the masking tape.
8. Mark the center of each hole and drill with 8.5mm (21/64") drill bit. Figure 2.

**FIGURE 2**

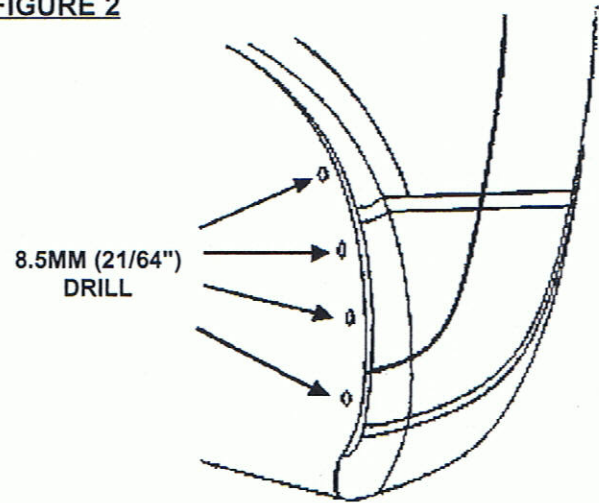

9. Mount part, inserting push pins in holes without pushing the head into the body of the push pin. Figure 3.

**FIGURE 3**

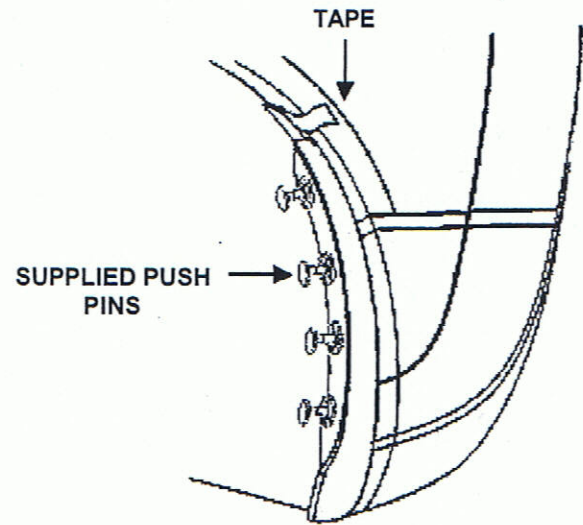

10. Remove the tape liner from the bottom of the tape. Push part to fascia from bottom of part, going up and against lower fascia first, ironing the tape to fascia. Figure 4.

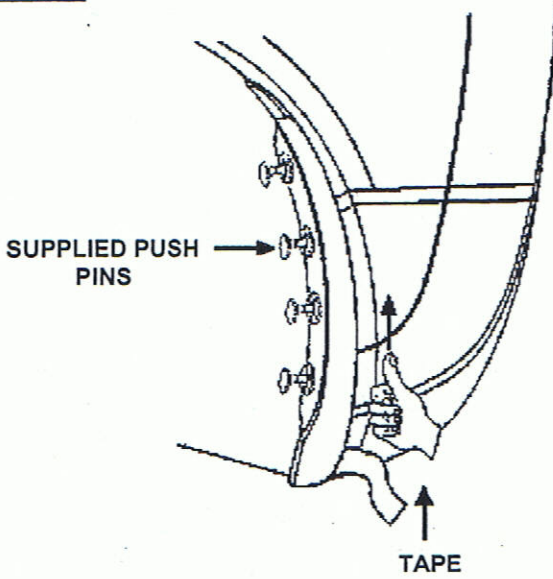
**FIGURE 4**

11. Remove tape liner from top of tape. Push part against fascia from lower point going up, making sure the top end locator engages the edge of the fascia. Figure 3.
12. Press the guard against the fascia, ironing the tape with 20-30 lbs. force. Figure 5.

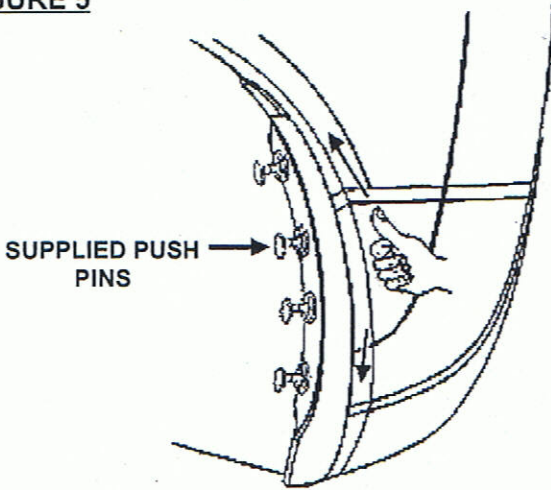
**FIGURE 5**

13. Push all four pin heads into pin body.
14. Repeat the procedure for the opposite side.